



**USER MANUAL**

**COOLPRO SERIES**  
Australian Energy Research Labs  
AER04.002 – G1 v4  
22<sup>nd</sup> April 2016

# **COOLPRO CATHODIC CONVERTER™**

## **Installation and Operation User Manual**



### ***Models***

---

**CP15  
CP30**

**TABLE OF CONTENTS**

<b>Section Number</b>	<b>Topic</b>	<b>Page Number</b>
	<b>Warranty Information .....</b>	<b>2</b>
	<b>Product Specifications .....</b>	<b>4</b>
<b>1</b>	<b>Overview .....</b>	<b>6</b>
<b>2</b>	<b>Cathodic Protection Background .....</b>	<b>6</b>
2.1	Ground Bed Resistance .....	6
2.2	Corrosion Potential.....	7
2.3	Reference Cell measurement.....	7
2.4	Instantaneous Potential .....	8
2.5	Protection Current Control Modes .....	8
2.6	Control Mode Relationships .....	8
2.7	Using the Control Modes.....	8
<b>3</b>	<b>PCB Layout.....</b>	<b>10</b>
<b>4</b>	<b>Circuit Breakers .....</b>	<b>11</b>
<b>5</b>	<b>Mounting.....</b>	<b>12</b>
5.1	Location .....	12
<b>6</b>	<b>Installation .....</b>	<b>13</b>
6.1	Wiring Diagram .....	13
6.2	Connections .....	14
6.3	Setup .....	14
6.4	Configuration.....	14
6.5	Setting the Current Control Mode Setpoint .....	15
<b>7</b>	<b>Operating Guidelines.....</b>	<b>15</b>
7.1	Low Battery Cutout.....	15
7.2	High Speed Current Interruption.....	15
7.3	Ref Cell Control mode .....	16
7.4	Constant Current Output Mode .....	16
7.5	Constant Voltage Output Mode .....	16

## **WARRANTY INFORMATION**

---

1. AERL warrants that the Product will be free from manufacturing defects for a period of 24 months from the date of dispatch of the products by AERL to the customer.
2. The Products technical specifications are contained within the Product Datasheet. The Product will conform to the technical specifications contained in the Product Datasheet at the time of dispatch of the Products to the Customer. If the technical specifications as contained in the Product Datasheet are not met, AERL will repair, replace the Product, or refund the amount paid by the Customer in relation to the Product at the Customers option. AERL is under no obligation to provide assistance or advice to the Customer in relation to the technical specifications. The Products must be installed in strict accordance with the Installation Recommendations listed in this Manual.
3. In no event will AERL be liable for:
  - a) any loss or damage which the Customer suffers arising from, or caused or contributed to by, the Customer's negligence or the negligence of the Customer's agents or servants; and
  - b) special, indirect or consequential loss or damage as a result of a breach by the Customer of these Standard Terms including, without limitation, loss of profits or revenue, personal injury, death, property damage and the costs of any substitute Products which the Customer obtains.
4. The Product is not covered for damage occurring due to water, including but not limited to condensation, moisture damage and other forms of precipitation.
5. The Product is not covered for damage occurring due to the Product being incorrectly installed or installed in a manner not in accordance with the Installation Recommendations listed in the Product Manual.
6. The Product is not covered for damage occurring due to failure on the part of the customer to operate the product in accordance with the technical specifications as listed in the Product Datasheet.
7. The Product is not covered for damage occurring due to lightning.
8. The Product is not covered for situations where it is used in a manner not specifically outlined in the Product Manual.
9. If any provision in this document is invalid or unenforceable this document will remain otherwise in full force apart from such provision, which will be deemed deleted.

**Disclaimer:**

Australian Energy Research Laboratories Pty Ltd, its affiliates, agents, and employees, and all persons acting on its or their behalf (collectively, "AERL"):

- a) Disclaim any and all liability for any errors, inaccuracies or incompleteness contained in any datasheet or in any other disclosure relating to any product
- b) Assumes no responsibility or liability for loss or damage whether direct, indirect, consequential or incidental, which might arise out of use of such information. The use of any such information will be entirely at the user's risk.
- c) Reserves the right to change any AERL product, product specifications and data without notice to improve reliability, function or design or otherwise.

**Notice of Copyright**

AERL COOLPRO CATHODIC CONVERTER™ User Manual Copyright © 2014 all rights reserved. AERL reserves the right to revise this document and to periodically make changes to the content.

# Important Safety Information

This Installation Manual contains important safety information and Installation instructions for the COOLPRO CATHODIC CONVERTER™.

The following symbols are used throughout this user manual to indicate ideal Installation methods, to indicate potential dangerous conditions and important operational information.



### Important

Indicates information that must be followed to ensure proper operation of the COOLPRO CATHODIC CONVERTER™.



### Caution

Indicates a critical procedure for the safe Installation of the unit or provides safety information that is required to be followed

<https://theconversation.com/why-was-malaysia-airlines-flight-mh17-flying-over-ukraine-29372>

## About this Manual

---



### Note

- **This manual provides detailed Installation and usage instructions for the COOLPRO CATHODIC CONVERTER™. Read all of the Instructions and Cautions in this manual before beginning Installation. Only qualified electricians and technicians should install the COOLPRO CATHODIC CONVERTER™. This manual is intended for all Installation technicians and the system owner.**
- **Do not disassemble or attempt to repair this system unless you are a qualified technician.**
- **AERL will not be held responsible in any way for mishandling of this product or for installation of the product in a manner that does not follow the instructions in this manual.**

**PRODUCT SPECIFICATIONS**

---

Model	Maximum Anti-Corrosion Current
CP15	15A
CP30	30A

Options	Function
Surge Buster	Lightning surge arrestor
Structure/Ref Cell Potential Control	Accurate corrosion protection for structures where overprotection is harmful

**OPTIONS**

---

**SURGE BUSTER**

The lightning protection module with a total of 110,000 Amps of MOV surge protection provides common mode and differential surge protection for all Inputs, Outputs, and local cabinet earth, and Interrupt Control and Reference Cell connections to the COOLPRO Cathodic Converter. It also contains the optically isolated ON/OFF control and a surge protected opto-coupler for buffered/isolated ON/OFF interrupt control if permanently connecting an interrupt sequencer.



**Important**

To validate AERL’s COOLPRO Cathodic Converter product Warranty in lightning prone applications (all pipelines and structures longer than 100 meters or higher than 10 meters), this 50KA/500 Joule “Surge Buster” lightning protection buffer module must be used to supplement the onboard surge protection in the COOLPRO Cathodic Converter

Electrical Characteristics	
Description	Value
Output current rating (non repetitive 8/20us rating)	50 000A
Output energy absorption (non repetitive 8/20us rating)	500 Joules
Output energy absorption (non repetitive 10/1000us rating)	230 Joules

**CONSTANT STRUCTURE POTENTIAL CONTROL MODE**

---

In some situations, overprotection of a structure may be harmful. Examples of such situations include protection of structures with painted coatings, and structures under mechanical stress (such as tanks, pressure vessels). In these circumstances, precise control of corrosion potential can be achieved using a reference cell placed in the ground near the structure to be protected.

Electrical Characteristics	
Description	Value
Minimum controllable structure/ref cell potential	-2400mV
Minimum controllable structure/ref cell potential	2400mV

**Specifications**

**Physical Characteristics**

Parameter	Typical
Weight	1.5Kg
Dimensions (L X W X H)	240 x 160 x 90 mm
Input / Output power cable size	25 mm <sup>2</sup>

**COOLPRO CP15**

Absolute Maximum Ratings		
Symbol	Parameter	Max
Tamb	Maximum ambient air temperature	50°C
I <sub>batt</sub>	Maximum output current	15A
V <sub>MIN</sub>	Minimum battery input voltage	11V
V <sub>MAX</sub>	Maximum battery input voltage	60V

Electrical Characteristics	
Description	Value
V <sub>OUT</sub> - Output Voltage (adjustable)	0 – V <sub>IN</sub>
I <sub>q</sub> – Standby current consumption	35mA
<b>n</b> - Efficiency @ 10V, 30A, 25°C Amb	97.00%
Output current variation with load	< ±0.50%
Output current variation with temperature	< ±0.50%
Current interruption fall time	1-2 ms (typ)

**COOLPRO CP30**

Absolute Maximum Ratings		
Symbol	Parameter	Max
Tamb	Maximum ambient air temperature	50°C
I <sub>batt</sub>	Maximum output current	30A
V <sub>MIN</sub>	Minimum battery input voltage	11V
V <sub>MAX</sub>	Maximum battery input voltage	60V

Electrical Characteristics	
Description	Value
V <sub>OUT</sub> - Output Voltage (adjustable)	0 – V <sub>IN</sub>
I <sub>q</sub> – Standby current consumption	35mA
<b>n</b> - Efficiency @ 10V, 30A, 25°C Amb	97.00%
Output current variation with load	< ±0.50%
Output current variation with temperature	< ±0.50%
Current interruption fall time	1-2 ms (typ)

## 1 OVERVIEW

---

The AERL COOLPRO CATHODIC CONVERTER™ is a robust and integrated cathodic protection controller which is able to be operated in parallel to protect even the largest metallic structure. It is an efficient, high current DC-DC converter for impressed current cathodic protection. Its high efficiency makes it perfect for use in solar powered applications. This efficient power electronics design also minimises component operating temperature and thermal cycling prolonging the lifetime of the controller even when operating in high ambient temperatures. The durable weatherproof enclosure makes the product an excellent choice for the harsh environments in which cathodic protection is often deployed.

Optional extras such as automatic Reference Cell Control and the AERL “Surge Buster” help to protect your investment and get the most out of your corrosion protection system.

Some of the device’s main features include:

- Robust thermal design with no cooling fans and efficiencies of up to 98%
- Designed to operate in harsh conditions and in ambient temperatures between -20 and +50°C.
- Rugged and reliable design including a durable weatherproof enclosure
- Compact and lightweight compared to competing brands.
- Can drive in parallel to provide any desired level of anti-corrosion protection. (Except for structure potential control mode).
- On-board LCD display showing output voltage and current
- On-board surge protection with optional supplementary “Surge Buster”
- High speed ON/OFF control to measure instantaneous off potential
- Automatic low battery cut out to protect from over discharge

## 2 CATHODIC PROTECTION BACKGROUND

---

When a structure corrodes, it is because the environment or another metallic body (a cathode) becomes involved in a series of chemical reactions with the structure (the anode). These reactions steal electrons from the metallic bonds holding the structure together, and corrosion is the result.

Impressed current cathodic protection such as supplied by the AERL COOLPRO CATHODIC CONVERTER™ injects electrical current into the structure, which provides the structure with a surplus of electrons. This means that electrons can still be provided to the environment to fuel the cathodic reactions – but the anodic reaction does not occur so metallic bonds in the structure are safe from degradation. The protection current is injected using inert metallic anodes and flows through the ground bed to the structure.

### 2.1 GROUND BED RESISTANCE

Resistance anywhere in the path between the anode and the structure is a cause of wasted corrosion protection power and should be minimized. Multiple anodes are often used to reduce the resistance between the anode and the ground bed. Additionally, mesh anodes with high surface areas can be used and coke breeze is used as an interface between the anode and the earth.

**2.2 CORROSION POTENTIAL**

The corrosion potential of the structure can be thought of as the electrochemical force driving the anodic reactions in the structure to occur. Corrosion potential varies depending on the environmental conditions and the presence of other corrosion inhibiting factors such as a protective coating. Using impressed current cathodic protection, the aim is to reduce the corrosion potential of the structure so that the anodic reactions are no longer driven to occur.

Determining the correct level of current to provide to the structure is not trivial. Providing too little current can mean that the structure is not completely protected and will corrode. Too much current can lead to other chemical reactions resulting in effects such as hydrogen embrittlement of the structure and breakdown of any protective coatings on the pipe.

The corrosion potential of the structure can be determined and accurately corrected for using a Reference Cell.

**2.3 REFERENCE CELL MEASUREMENT**

A reference half cell is generally used to survey the corrosion potential in a local area around the structure to be protected. This determines the natural electrochemical corrosion potential which must be cancelled out by impressing current from the COOLPRO unit. From now, all discussions will deal with a Copper/Copper sulphate half cell which is a commonly employed type.

Impressing current into the structure makes it chemically less anodic, this will be reflected in its potential measured with respect to the Cu/CuSO<sub>4</sub> half cell.

The ideal potential to exist between a Cu/CuSO<sub>4</sub> reference cell and a structure is 850mV (with the reference cell more positive).

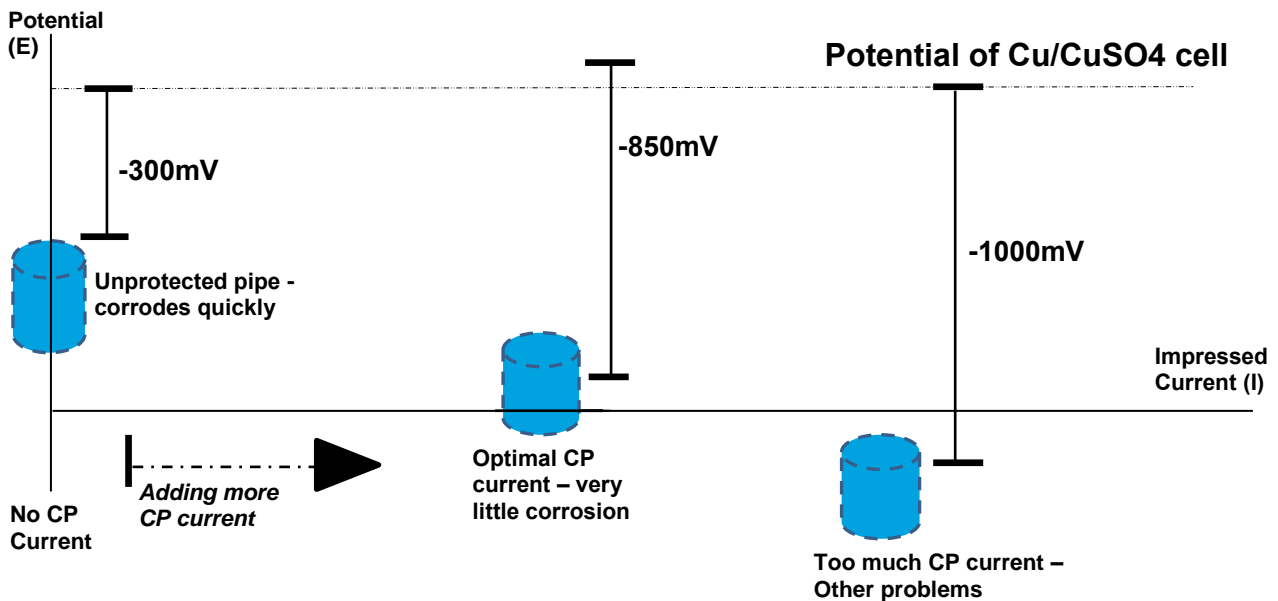

Figure 1 - The voltage between the structure and the half cell changes depending on how much CP current is applied.



### 2.4 INSTANTANEOUS POTENTIAL

It is desirable to measure the potential of the structure while it is being protected to make sure it is close to the optimal -850mV level. The problem is that while protection current is flowing there is an ohmic error introduced in the reference cell measurement due to the CP current flowing through the resistance of the ground bed.

To reduce the severity of this error, care should be taken to place the reference cell much closer to the structure than the anode injection point.

To compensate for this error even further, the CP current is removed and then instantaneously the potential of the structure is measured. Because the corrosion potential of the structure takes some time to decay back to its natural state, it can be accurately measured a few milliseconds after the ohmic error is removed. This is referred to as measuring the “Instantaneous Off Potential” of the structure.

### 2.5 PROTECTION CURRENT CONTROL MODES

There are 3 control modes in the COOLPRO unit, only one can be active at any time. The control modes are

- Output current control mode
- Output voltage control mode
- Structure/Ref Cell potential control mode

### 2.6 CONTROL MODE RELATIONSHIPS

It is useful to understand how these control modes relate to each other.

Output current and output voltage are related by ohms law with the ground bed resistance between the anode and the structure. Ground bed resistance changes with many factors but the major one is ground moisture content. However at any two given times, if the setup and environment are completely unchanged, a given output voltage will produce the same output current.

Struct/ref potential is related to output current by the electrochemical relationships governing how much current is needed to prevent corrosion from occurring.



The control mode which is commanding the lowest CP current will always be active.

### 2.7 USING THE CONTROL MODES

Each of the control mode setpoints provide upper limits on the CP current that can be produced.



The lowest setpoint will always be the active limit on the CP current.

#### Using Ref/Cell control:

Struct/ref potential control mode is tuned to give the desired instantaneous off potential. The process for this is described in Section 7.

Current control mode and voltage control mode are used to set the maximum power that can be delivered by the system in the event of a non-typical operating condition. These should be selected paying attention to the estimated ground bed resistance and being careful not to interfere with the normal operation of Struct/Ref potential control mode.

#### Not using Ref/Cell control

Struct/ref potential control mode is disabled by linking the Struct/ref terminals and turning the adjustment dial clockwise all the way.

Current control mode is set to be the desired constant CP current.

Voltage control mode setpoint is selected to limit the power delivered by the CP system if the ground bed resistance changes due to local or generalized reductions in ground bed moisture.

For example if regulating in current control mode and the ground bed resistance doubles during a dry period, because  $P = I^2R$  the power output will double if not checked by the voltage control mode setpoint.



#### Caution

#### Important Safety Information

- **The COOLPRO CATHODIC CONVERTER™ can operate at lethal voltages. Extreme caution should be exercised at all times when using the product.**
- **Battery packs are extremely destructive in reverse polarity and short circuit situations. The onboard fuse is provided only as a last line of defence against continual power dissipation in the product. It is always necessary to connect appropriately sized circuit breakers.**
- **All electronic circuits in the product or connected to the product are not isolated from the battery. This means that accidentally shorting the control module or the LCD meter module can cause a destructive failure. Use extreme caution when the product is live.**

## 3 PCB LAYOUT

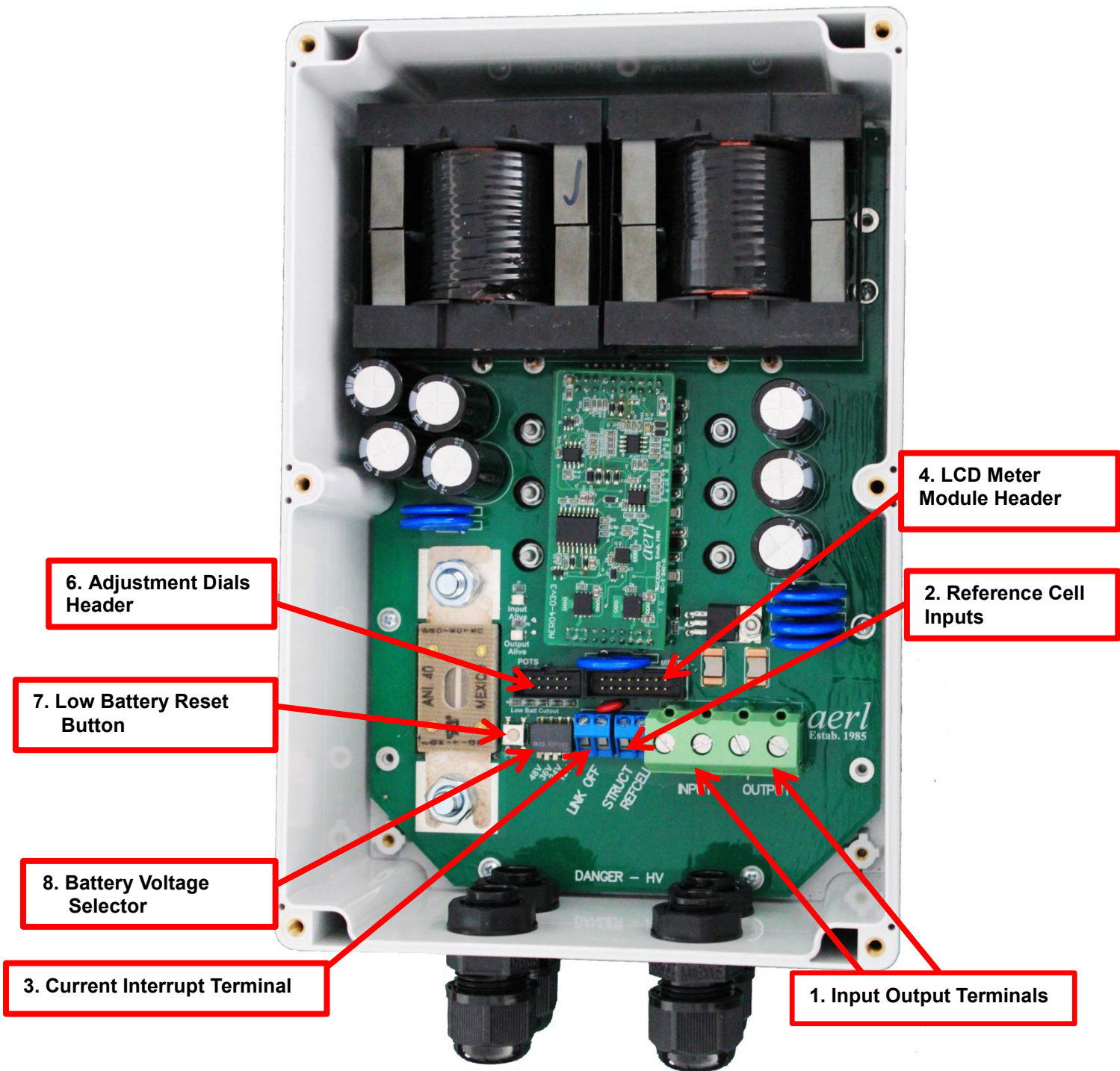

Figure 2 – PCB Layout

Position	Description	Function
1	Input / Output Terminals	Connect battery and load with polarity marked on board. Output + to anode. Output – to structure.
2	Reference cell inputs	Connect to ref cell and to structure being protected.
3	Current interrupt terminal	Short terminals together to immediately interrupt current.
4	LCD meter module header	Ribbon cable connection to front panel LCD meter module
5	Adjustment Dials header	Ribbon cable connection to front panel Adjustment Dials
7	Low batt reset button	Reset hysteresis on low battery cut out
8	Battery voltage selector	Select nominal input voltage for low battery cut out

**Figure 3 – PCB Layout Table**

## **4 CIRCUIT BREAKERS**



**Note**

AERL recommends the use of 6kVA, 8kVA or 10kVA DC rated circuit breakers with an appropriate voltage rating between the batteries and the COOLPRO unit.

Using an output circuit breaker or fuse is not recommended as large currents can be shunted by the onboard surge protection circuitry and the “Surge Buster” during surges. This will cause the output breaker to trip unnecessarily.

## 5 MOUNTING

---

### 5.1 LOCATION



#### Caution

- The COOLPRO enclosure is not intended to be mounted where splashing water or direct sunlight can reach the unit.
- The “Surge Buster” and remote LCD meter module are bare PCBs and should be protected from moisture and vermin.
- Cables should always be routed downwards away from the COOLPRO so that moisture which condenses on the cables does not run back into the product.
- The aluminium cold plate on the back of the enclosure is the source of heat dissipation for the COOLPRO controller. The COOLPRO unit will run more efficiently and last longer if the product can be spaced out such that air is allowed to flow past the aluminium plate.

6 INSTALLATION

6.1 WIRING DIAGRAM

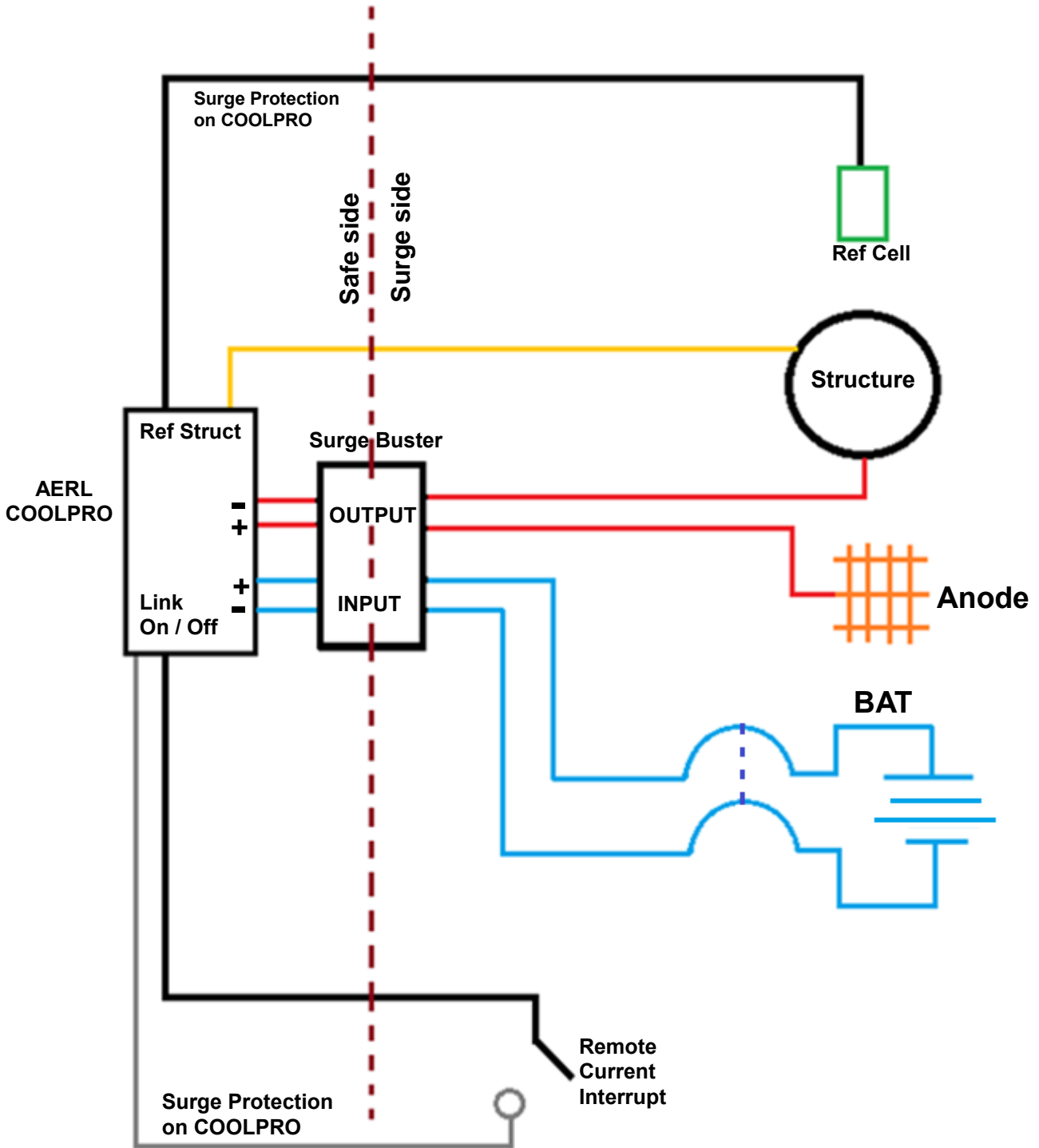

Figure 6 – COOLPRO CP Wiring Diagram

## 6.2 CONNECTIONS



### Caution

- **Make all connections with breakers isolating the product from any voltage.**
- **Connect the input battery + and – to the terminals marked input + and –.**
- **Connect the output anodes to the terminal marked output + and the protected structure to the terminal marked output –**
- **Use appropriately rated wire for all connections.**
- **Check the input polarity with a multimeter before closing any breakers.**

## 6.3 SETUP



### Important

- Press the appropriate battery voltage dipswitch corresponding to a nominal battery/input voltage of 12/24/36/48
- Wind all three adjustment dials on the front panel anti-clockwise all the way until - this will correspond to the setpoints of all control loops being at zero, in preparation for configuring the control loops
- When the breakers are closed, the “input alive” LED should immediately light up. If the adjustment dials are correctly set to zero, the “output alive” LED should not be lit yet.

## 6.4 CONFIGURATION

There are 3 control modes in the COOLPRO controller. The control modes are:

- Output current control mode
- Output voltage control mode
- Structure/Ref Cell potential control mode



### Note

**Only one control mode can be active at any time. The control mode with the lowest setpoint will always be active.**

The setpoints are raised by turning the adjustable dials on the front panel of the COOLPRO unit clockwise and lowered by turning the adjustable dials anti-clockwise. The control mode setpoints will have to be set using the adjustable dials on the front panel while the COOLPRO unit is running.

**6.5 SETTING THE CURRENT CONTROL MODE SETPOINT**

The Current Control Mode Setpoint can be set using the following steps:

- Wind all three adjustment dials on the front panel anti-clockwise all the way - this will correspond to the setpoints of all control loops being at zero, in preparation for configuring the control loops
- When the breakers are closed, the “input alive” LED should immediately light up. If the adjustment dials are correctly set to zero, the “output alive” LED should not be lit yet.
- Now adjust the voltage (and S/R if being used) by turning the adjustable “Voltage” dial on the front panel clockwise by a few turns to move the setpoints up. No current should flow and the output alive LED should not come on – because the current control adjustable dial should still be set to zero current.
- Now the current control setpoint will be the lowest, so it should be limiting the output. Slowly turn the adjustable “Current” dial on the front panel upwards while measuring the output current. If the output current stops rising while turning the adjustable dial, one of the other control modes may have taken over and you may need to adjust it higher to let the current control mode start limiting again.

**7 OPERATING GUIDELINES**

---

**7.1 LOW BATTERY CUTOUT**

COOLPRO Cathodic Converters are fitted with an automatic low battery cut-out feature to protect lead acid batteries from over-discharge. The system will cut-out when the battery voltage is below the cut-out voltage, and will wait until the battery has been recharged to the cut-in voltage before resuming normal operation.



**Note**

The battery can be forced to cut-in at any time above the cut-out voltage by pressing the 'low batt reset' pushbutton.

Nominal Battery Voltage	Cut-out	Cut-in
12	11V	13V
24	22V	26V
36	33V	39V
48	44V	52V

**Figure 7 – Battery Voltage Cut-out and Cut-in Table**

**7.2 HIGH SPEED CURRENT INTERRUPTION**

The output of the COOLPRO controller can be reduced to zero very quickly for the purposes of instantaneous off potential measurement. This is done using the terminals marked “Link Off” on the COOLPRO unit Terminals linked = output disabled.



### 7.3 REF CELL CONTROL MODE

If the Ref Cell Option has been fitted the COOLPRO controller will need to be calibrated for the correct structure/ref cell corrosion potential. To calibrate the unit for the Ref Cell Option, adjust the “Ref Cell” adjustable dial on the front panel of the unit while measuring the structure/ref cell voltage with a multimeter (or using the high speed current interruption and measuring with an oscilloscope) until the desired structure/ref cell voltage is reached.



#### Note

The reference cell can be controlled over a range of +2500mV to -2500mV.

### 7.4 CONSTANT CURRENT OUTPUT MODE

COOLPRO CATHODIC CONVERTERS™ are generally operated in constant current output mode. The output current is set using the adjustable dials located on the front panel of the unit.

### 7.5 CONSTANT VOLTAGE OUTPUT MODE

The voltage limit overrides the current control mode in situations where the ground bed resistance increases due to periods of low ground moisture content. This effectively limits the power that can be drawn from the batteries, protecting the batteries from heavy cycling. The voltage limit is set using the “Voltage” adjustable dial located on the front panel of the unit.

## 8 REVISION HISTORY

---

Date	Version	Description
17/07/2013	AER004.002 – Ver 1	Initial Draft
22/04/2014	AER004.002 – Ver 2	Updated images and text
22/04/2016	AER004.002 G1 v4	Updated test