

Terminals

Terminal Functions

- **1 through 4:** Rapid Shutdown terminals.
 - Terminals 1 and 3 connect to normally-closed contacts on the RSI (Rapid Shutdown Initiator), which is part of the OutBack ICS Plus system.
 - NOTE:** If not using a rapid shutdown, use a jumper wire to connect these terminals. If the terminals are left open, the controller shuts down.
 - Terminals 2 and 4 are parallel connections. They can connect to additional FLEXmax 100 controllers to perform the same function with a single RSI.
- **5 and 6:** Auxiliary (Aux) terminals.
 - Used for diversion control and other functions.
- **7 and 8:** Battery Sense terminals.
 - See Wiring section.

Environmental / Safety Specifications

Environmental Category	Outdoor
Enclosure Type	Type 3R
Suitable for wet locations	Yes
Pollution degree classification	PD3
IP rating	IP54
Ambient temperature range	-20°C to 60°C (-13°F to 140°F)
Relative humidity rating	4% to 100% Condensing
Maximum altitude rating	10,000 feet
Overvoltage category	PV: OV Cat II Batt: OV Cat II

NOTES:

- ❖ Unit output is derated above 25°C (77°F)

LED Indicators and FLEXmax 100 Symbols

(See **A** in wiring section)

Symbol	Indicator	Pattern	Controller Status	Voltage
	Charging		Off = less than 10 W PV available	Battery rest
			Bulk, Equalize, or GT Mode	
			Absorption	
			Float	Float
				≥ 1.91 Vpc
	Status		Bulk or Absorption	
			Float	
			GT Mode	
			Battery Discharge	< 1.91 Vpc
			Critical Battery Discharge	< 1.75 Vpc
			Equalize	≤ EQ
	Auxiliary		AUX Active	
	Fault		Ground Fault Shutdown or other fault	
			All off (with PV power available) = Rapid Shutdown	



IMPORTANT:
Not intended for use with life support equipment.

Date and Revision

October 2017, Revision B

FLEXmax 100

Included in Package

- FLEXmax 100 Charge Controller
- 2 x Mounting Bracket
- Silicone Grease Package
- Cooling Fan (outdoor-rated)
- MicroSD Card (already installed)

Dimensions

Height: 18.8" (47.1 cm); with fan 22.06" (56.0 cm)
Width: 8.8" (22.4 cm)
Depth to Wall: 6.0" (15.2 cm)

Mounting

- The FLEXmax 100 must be mounted upright at least 36" (91.4 cm) above the ground or floor. Shade is recommended when installing outdoors.
- Conduit hubs must be connected to the conduit before connecting to the FLEXmax 100.
- Clearance requirements are a minimum of 6" (15.2 cm) above and below the controller.
- The unit can be mounted using either brackets (see steps 1 through 4 in **A**) or keyhole slots (see **B**) on a secure mounting surface. Follow the numbered steps.
- The cooling fan must be installed prior to operation. It should be installed after mounting the controller.

This guide is intended for use by anyone required to install and operate this equipment. Be sure to review this guide carefully to identify any potential safety risks before proceeding. Failure to install or use this equipment as instructed can result in damage to the equipment that may not be covered under the limited warranty. This product is only serviceable by qualified personnel. Additional information on programming and advanced functions is available in the FLEXmax 100 Owner's Manual.

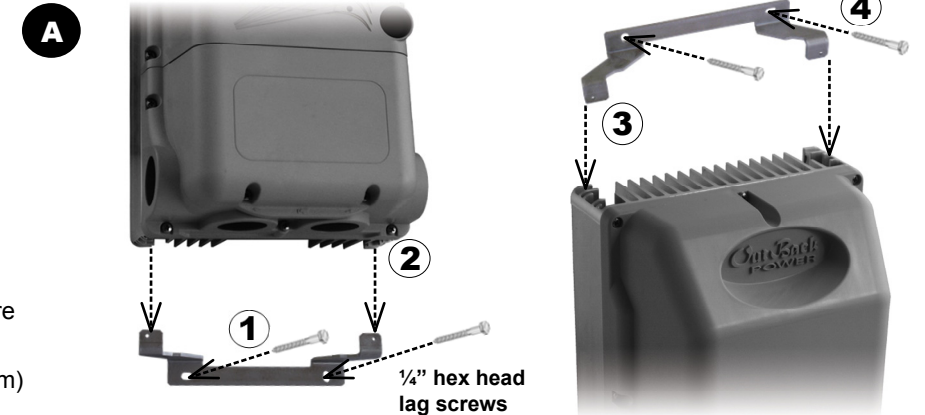

Bracket hole spacing: 5.13" (13.0 mm)
Vertical space between upper and lower bracket holes: Approximately 20" when mounted

Fan Mounting

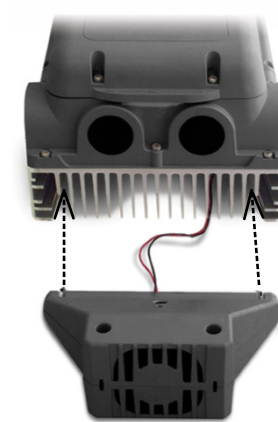

Fan Wiring

Fan Wire and Plug

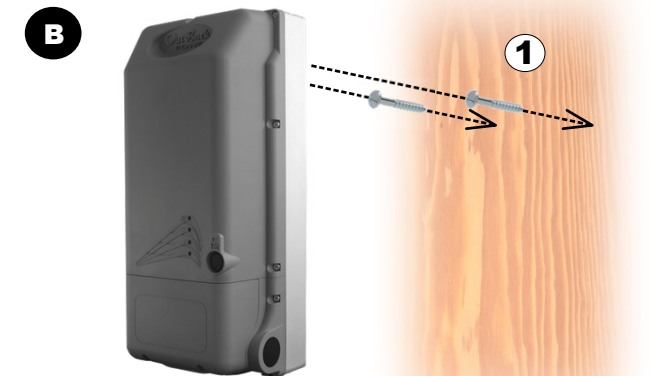
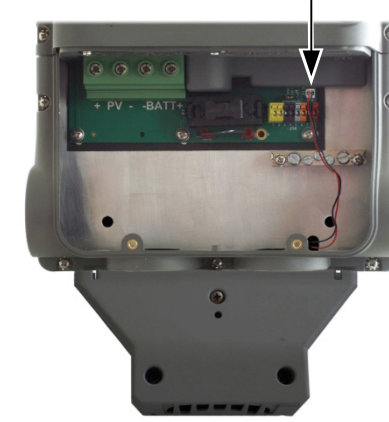

Keyhole Slots
(#14 slotted wood screws, 7.9" or 20.1 cm spacing)

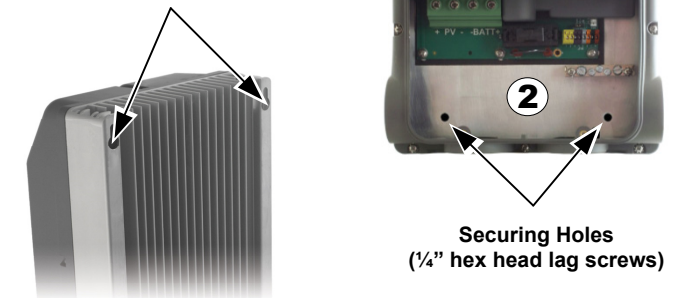

Securing Holes
(1/4" hex head lag screws)

WARNING: Shock Hazard
When the PV array is exposed to light, it supplies a DC voltage to the charge controller.

5 minutes
WARNING: Shock Hazard (Timed Discharge)
This product is equipped with capacitors which store energy until completely discharged.

DC LEGEND		
Negative		⊖
Positive		⊕
Ground		⊕

IMPORTANT: Before powering up the controller
The rapid shutdown terminals are left disconnected at the factory. The FLEXmax 100 will not power up until terminals 1 and 3 in **C** are connected together. See the back page for more information.

- Tighten all wire lugs and ground terminals to 4 Nm (35 in-lb) torque.
- Use copper wiring only (rated 90°C or higher). Refer to the NEC and other electrical codes for PV array cable sizing, length, and ampacity.
- Use #4 AWG (25 mm²) wire (**minimum**) for the controller output terminals to the batteries. They can accept up to #2 AWG (35 mm²).
- Use #6 AWG (16 mm²) wire (**maximum**) for the ground terminals.
- Negative-ground installation is depicted here. (The bond is shown in **D**.) Positive grounding is also permitted, but special arrangements are required.
- External disconnect and overcurrent protective devices must be sized and provided by the installer. For input circuit breakers, OutBack offers 40 Adc to 80 Adc devices. For the output, OutBack offers either 100 Adc or 125 Adc devices.
- This product supports the following nominal battery systems:
 - 24 volts
 - 36 volts
 - 48 volts

IMPORTANT: Example only
Actual wiring may vary from the system depicted here. All configurations must comply with local and national electric codes. Consult the local electric authority to ensure compliance.

IMPORTANT:
Wire sizes must comply with local and national codes. To comply with the NEC, input conductors and circuit breakers must be rated at 1.56 times the short-circuit current of the PV array.

CAUTION: Equipment Damage
When installing multiple controllers or the OutBack GFDI, follow all instructions shown in the *Owner's Manual*. Install only one bonding jumper for all controllers (**D**). The GFDI makes a negative-ground bond.

CAUTION: Equipment Damage
Do not use a power driver or other power tools to tighten wire terminals. This can damage them.

WARNING: Burn Hazard
The heat sink can become hot when the charge controller is operating. Use caution when touching it during operation.

NOTE: See the *FLEXmax 100 Owner's Manual* for more notes on all topics above. This also includes installation of rapid shutdown devices, multiple controllers, and ground fault operation (GFDI).

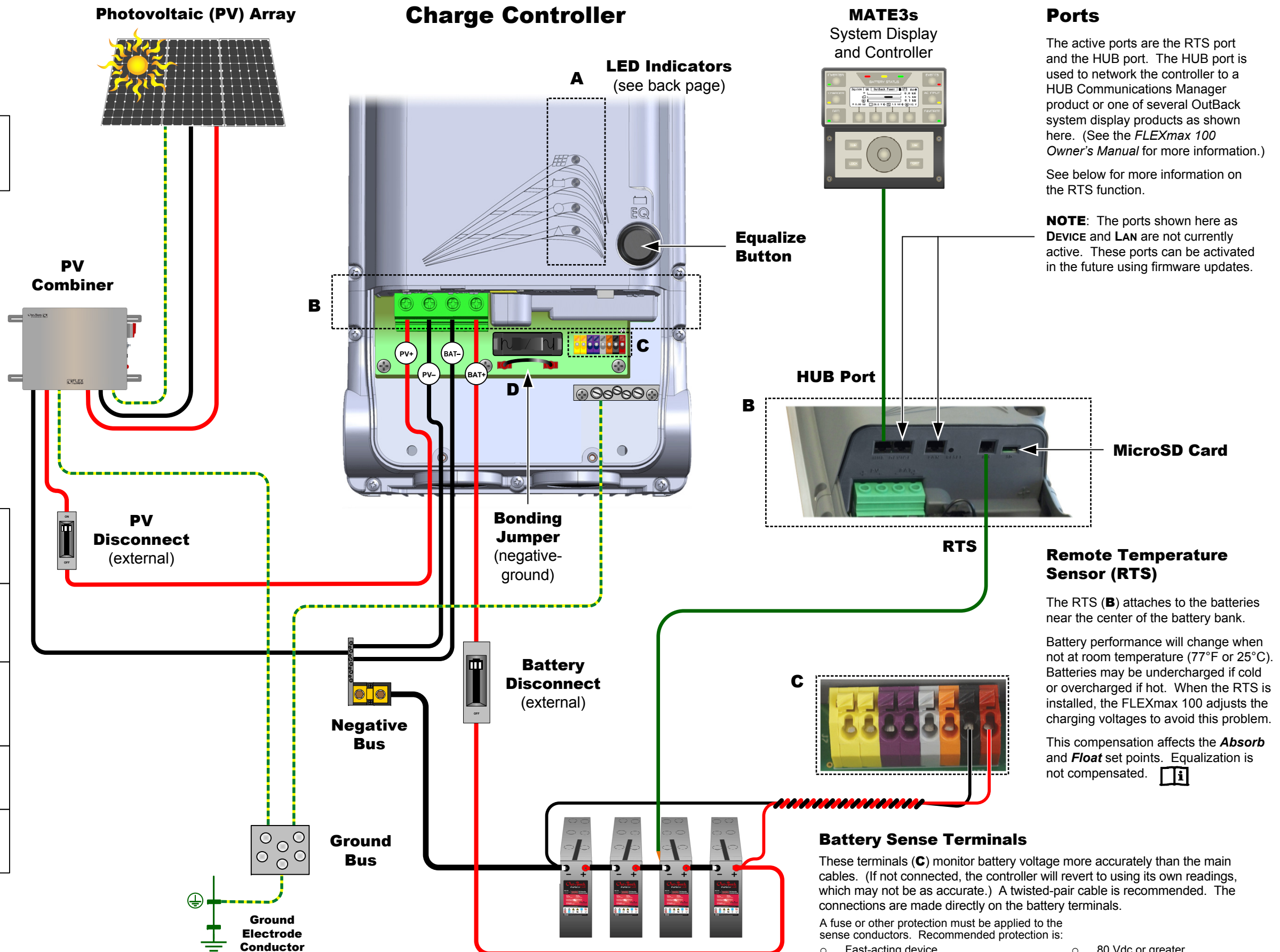

Ports
The active ports are the RTS port and the HUB port. The HUB port is used to network the controller to a HUB Communications Manager product or one of several OutBack system display products as shown here. (See the *FLEXmax 100 Owner's Manual* for more information.)

See below for more information on the RTS function.
NOTE: The ports shown here as **DEVICE** and **LAN** are not currently active. These ports can be activated in the future using firmware updates.

Remote Temperature Sensor (RTS)

The RTS (**B**) attaches to the batteries near the center of the battery bank.
Battery performance will change when not at room temperature (77°F or 25°C). Batteries may be undercharged if cold or overcharged if hot. When the RTS is installed, the FLEXmax 100 adjusts the charging voltages to avoid this problem.
This compensation affects the **Absorb** and **Float** set points. Equalization is not compensated.

Battery Sense Terminals
These terminals (**C**) monitor battery voltage more accurately than the main cables. (If not connected, the controller will revert to using its own readings, which may not be as accurate.) A twisted-pair cable is recommended. The connections are made directly on the battery terminals.
A fuse or other protection must be applied to the sense conductors. Recommended protection is:

○ Fast-acting device	○ 80 Vdc or greater
○ Cold resistance 10 ohms or less	○ 1 Adc or smaller